

## Bucha de Redução L/R CPVC

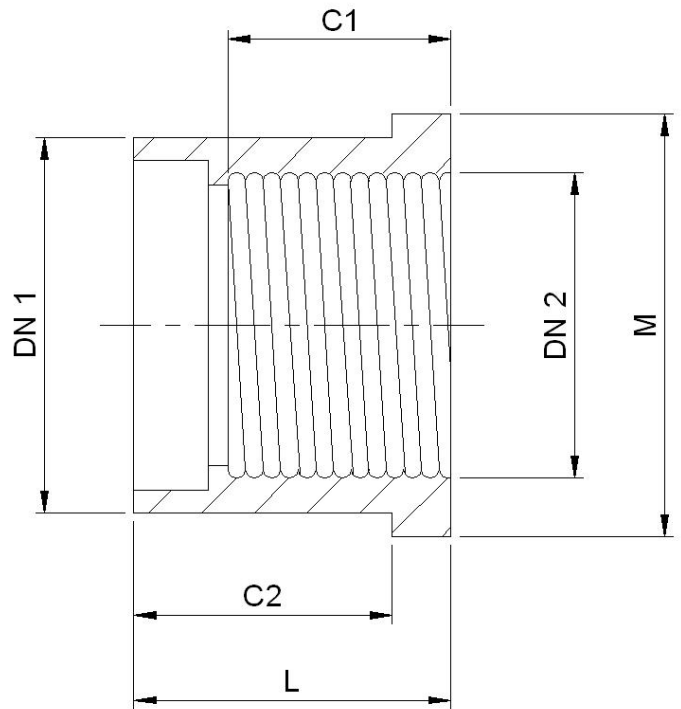
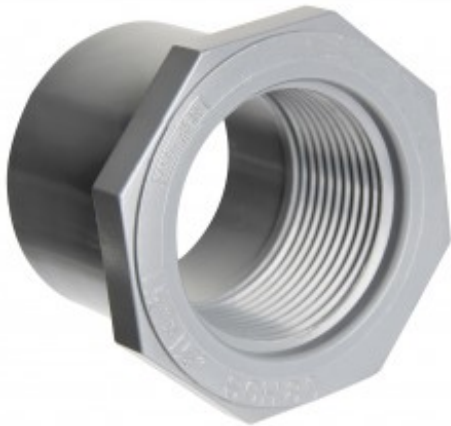

DN1 x DN2 (pol)	Código	C 1	C 2	M	L	Peso Aprox. (Kg)
D1 X D2 (inch)	Code	C 1	C 2	M	L	Weight Approx. (Kg)
3/8"X1/4"	9838052	15.00	19.00	21.00	25.00	0.01
1/2"X1/4"	9838072	15.00	21.00	24.00	26.00	0.01
1/2"X3/8"	9838073	15.00	21.00	24.00	26.00	0.01
3/4" x 1/2"	9838101	19.70	26.06	34.92	34.11	0.01
1" x 1/2"	9838130	19.38	30.02	42.79	38.10	0.03
1" x 3/4"	9838131	19.68	30.42	42.79	38.02	0.03
1.1/4" x 1/2"	9838166	20.39	33.14	52.50	42.67	0.06
1.1/4" x 3/4"	9838167	17.57	31.85	52.67	41.78	0.05
1.1/4" x 1"	9838168	20.62	33.09	52.47	42.75	0.07
1.1/2" x 1/2"	9838209	17.34	34.95	57.32	44.58	0.07
1.1/2" x 3/4"	9838210	20.49	36.27	59.00	46.08	0.07
1.1/2" x 1"	9838211	25.65	35.91	58.90	45.85	0.06
1.1/2" x 1.1/4"	9838212	22.88	34.92	57.40	45.11	0.10
2" x 1/2"	9838247	17.37	38.22	71.42	47.80	0.10
2" x 3/4"	9838248	20.39	38.96	70.10	48.87	0.10
2" x 1"	9838249	25.24	39.16	69.95	48.69	0.10
2" x 1.1/4"	9838250	25.32	39.01	69.97	48.82	0.09
2" x 1.1/2"	9838251	25.27	39.01	69.97	48.82	0.09

Continua na próxima página

Continuação da tabela

<b>DN1 x DN2 (pol)</b>	<b>Código</b>	<b>C 1</b>	<b>C 2</b>	<b>M</b>	<b>L</b>	<b>Peso Aprox. (Kg)</b>
2.1/2" x 1/2"	9838287	19.70	44.45	89.10	63.30	0.15
2.1/2" x 3/4"	9838288	19.68	44.45	89.10	73.20	0.20
2.1/2" x 1"	9838289	20.62	44.45	89.10	78.50	0.25
2.1/2" x 1.1/4"	9838290	22.88	44.45	89.10	69.30	0.20
2.1/2" x 1.1/2"	9838291	25.27	44.45	89.10	64.50	0.20
2.1/2" x 2"	9838292	25.40	44.45	80.97	49.61	0.15

**Obs.:** Todas medidas acima estão em milímetros (mm) , salvo indicação contrária.  
**As Buchas descritas acima poderão ser COMPOSTAS por duas ou mais Buchas**